

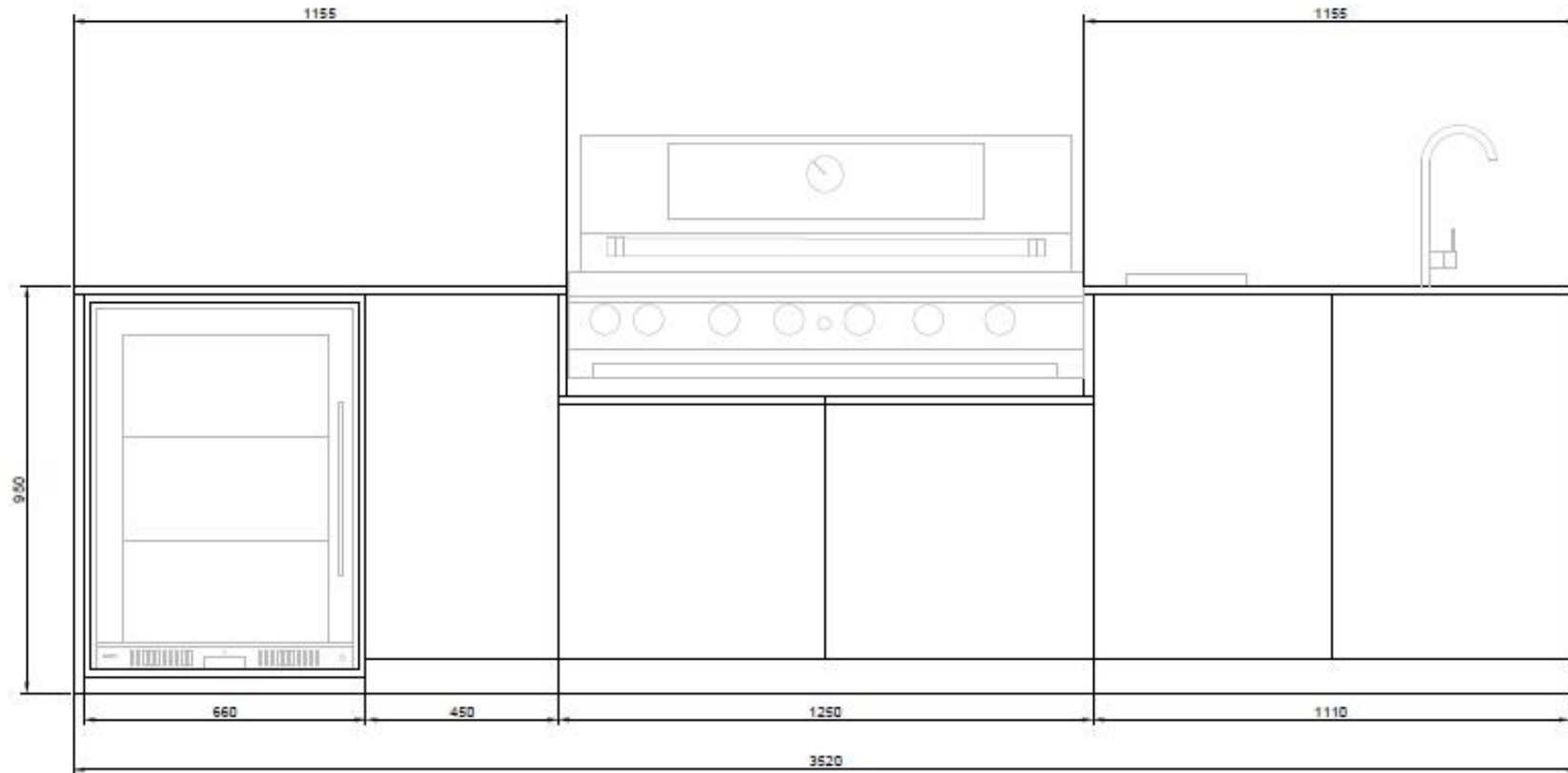

KAKADU Assembly Instructions





KAKADU - 3520mm

KAKADU Content List

Carcass Boxes

1 x HN660DWF (Fridge Unit Cabinet)

1 x HN4501D (Single Door Cabinet)

1 x HN12502BQ (BBQ Unit Cabinet)

1 x HN11102D (Sink Unit Cabinet)

Door Boxes

1 x HN660DWF – Kicker

1 x HN4501D – Door/Kicker

1 x HN12502BQ – Door/Kicker

1 x HN11102D – Door/Kicker

Stone Tops

8 pieces A-H

Appliances & Accessories

1 x EA60WFSX (Beverage Cooler)





1 x HN1200RBQ (6 Burner BBQ Hooded)

1 x ES510UM (Undermount Sink)

1 x PC1001SB (Sink Mixer)

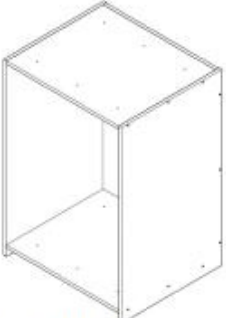
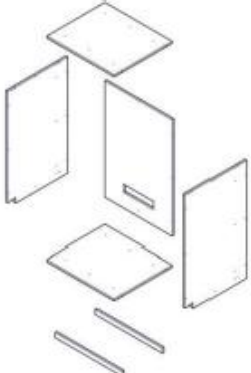
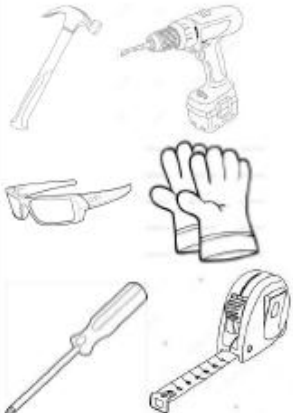

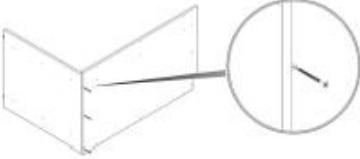
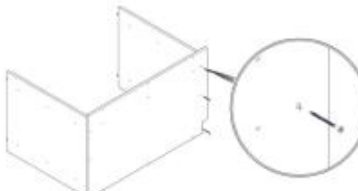



Carcass Assembly

Assemble Fridge Unit Cabinet HN660DWF as per assembly instructions provided using hardware supplied

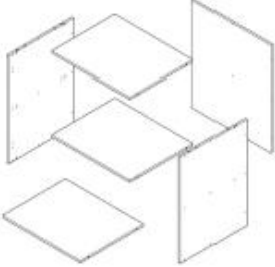
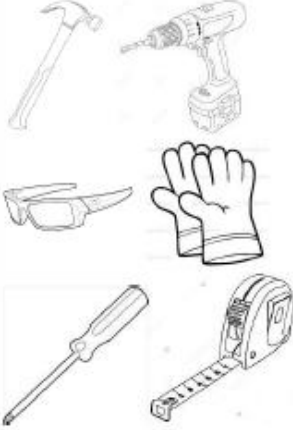
Assembly Instructions Suitable for 660 Fridge Base 	Panels Included 	Required Tools 	Hardware Supplied		
Hardware Supplied 	Fx26	Hx4 	Fx3 	Fx3 	
	Hx8				



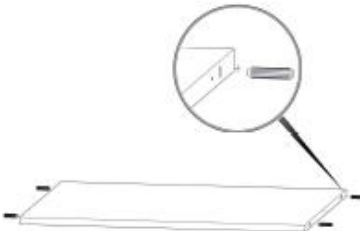
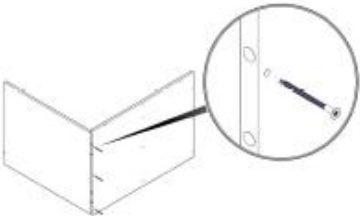
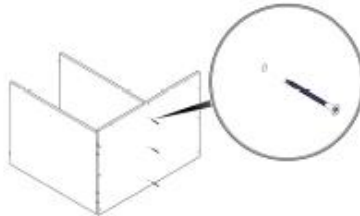

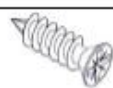





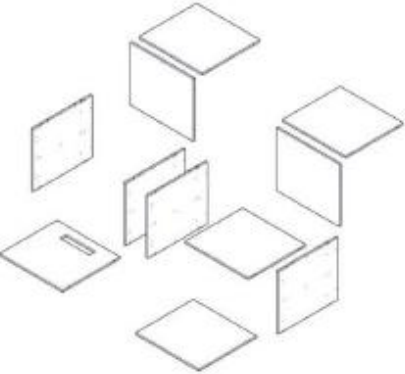



Carcass Assembly

Assemble Single Door Cabinet HN4501D as per assembly instructions provided using hardware supplied

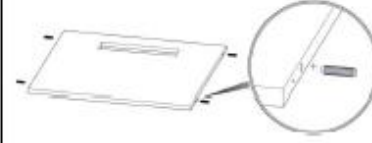
Assembly Instructions	Panels Included	Required Tools	Hardware Supplied	
<p>Suitable for 450mm Base Unit</p> 				Ax4
	Hx4	Fx3	Fx3	
	Ex1			
	Fx35			
	Gx8			
	Hx12			
	Ix2			











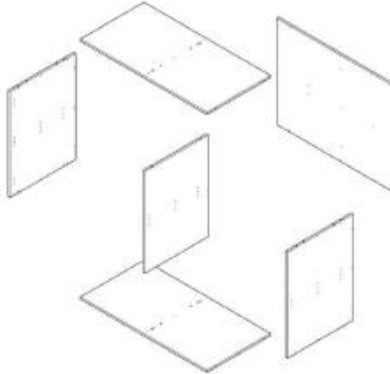
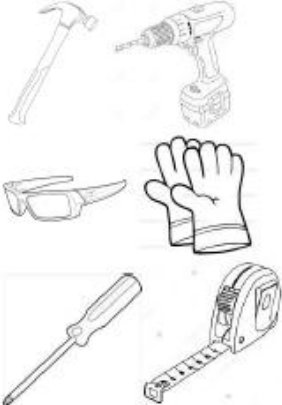



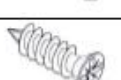

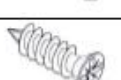

Carcass Assembly

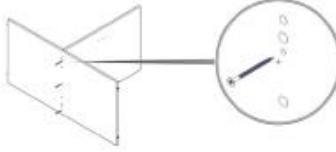
Assemble BBQ Unit Carcass HN12502BQ as per assembly instructions provided using hardware supplied

Assembly Instructions		Panels Included		Required Tools		Hardware Supplied	
Suitable for 1250mm BBQ Base Unit 						 Ax8  Bx8  Cx4  Dx4	
Hardware Supplied		Hardware Supplied		Hx4		Hx4	
	Ex2		Jx1	 			
	Fx58		Kx4				
	Gx16		Lx4				
	Hx20						
	Ix4						

Carcass Assembly

Assemble Sink Unit Carcass HN11102D as per assembly instructions provided using hardware supplied

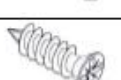
Assembly Instructions Suitable for 1110mm Base Unit (2 Door) 	Panels Included 	Required Tools 	Hardware Supplied														
Hardware Supplied <table border="1" data-bbox="302 927 674 1417"> <tr> <td></td> <td>Ex2</td> </tr> <tr> <td></td> <td>Fx59</td> </tr> <tr> <td></td> <td>Gx12</td> </tr> <tr> <td></td> <td>Hx16</td> </tr> <tr> <td></td> <td>Ix4</td> </tr> </table>		Ex2		Fx59		Gx12		Hx16		Ix4	Hx4 	Hx4 	Fx3 	 Ax6	 Bx6	 Cx4	 Dx4
	Ex2																
	Fx59																
	Gx12																
	Hx16																
	Ix4																

Carcass Installation

Floor Check

Using a spirit level (1200mm min) check the floor where you are planning to install the carcass units. Mark with a pencil indicating the highest and lowest sections of the floor



Carcass Installation

Wall layout

Refer to the KAKADU kitchen layout (pg. 2) and mark the cabinetry unit widths and heights making allowance for 20mm thickness of stone.

The finished joinery height recommended is 950mm



Carcass Installation

Placement and Connection of Carcass Units

Starting with HN660DWF place the unit in desired position and level off to the recommended height as marked on wall layout allowing 120mm void from the back of the unit to the wall to allow for services void (drill through service point as required)

Place HN4501D unit in desired position and level off to the recommended height using adjustable legs allowing approx 100mm void from the back of the unit to the wall for services void. (drill through service point as required) Once in place screw together both units using 28mm 8g wood screws (x6)

Place HN12502BQ unit in desired position and level off to the recommended height using adjustable legs allowing approx 100mm void from the back of the unit to the wall for services void. (drill through service point as required) Once in place screw together both units using 28mm 8g wood screws (x4)

Place HN11102D unit in desired position and level off to the recommended height using adjustable legs allowing approx 100mm void from the back of the unit to the wall for services void. (drill through service point as required) Once in place screw together both units using 28mm 8g wood screws (x4)

Check levels across all 4 connected cabinets and fix down to floor through adjustable leg base using a 6mm x 40mm concrete plug and 28mm screw

Stone Top Installation

Gluing of Stone Tops

Starting with stone pieces A&B place pieces one by one on HN12502BQ allowing 20mm past the front of the carcass. Using neutral cure clear silicone apply 10mm diameter dollops and apply pressure to tops

Apply stone piece C to side of HN4501D sitting on Stone piece A (silicone off)

Apply stone piece D to side of HN11102D sitting on stone piece B (silicone off)

Ensure alignment of stone pieces A-D

Apply stone piece E to side of HN660DWF ensuring that top of stone is flush with top of joinery unit (silicone off)

Apply stone piece F to side of HN11102D ensuring that top of stone is flush with top of joinery unit (silicone off)

Apply stone piece G to top of HN660DWF & HN4501D ensuring alignment with stone piece E&C

(silicone off)

Apply stone piece H to top of HN11102D ensuring alignment with stone piece D&F

(silicone off)

Door & Kicker Installation

Door Hanging

Starting with door pack HN12502BQ screw hinges on the 2 doors using pre-drilled holes and M5 screws provided. Attach doors to clip on plates located on the carcass sides

Repeat the above steps for door pack HN4501D & HN11102D

Kicker Placement

Starting with HN660DWF kicker apply neutral cure silicon to leg bases and blocks and press in position

Align HN4501D kickers, HN12502BQ kickers and HN11102D kickers repeating the above steps

Appliance & Accessory Placement

Beverage Cooler

Unpack and slide EA60WFSX (Beverage Cooler) into HN660DWF
(ready for installation by qualified electrician)

BBQ

Unpack and place HN1200RBQ (6 Burner BBQ Hooded) on to HN12502BQ
(ready for installation by qualified gas fitter)

Sink & Tap

Unpack and place ES510UM (Undermount Sink) and PC1001SB (Sink Mixer) into
HN11102D
(ready for installation by qualified plumber)